

## FEATURES

Latch-up immune under all circumstances  
 Human body model (HBM) ESD rating: 8 kV  
 Low on resistance: 6.5  $\Omega$   
 $\pm 9$  V to  $\pm 22$  V dual-supply operation  
 9 V to 40 V single-supply operation  
 48 V supply maximum ratings  
 Fully specified at  $\pm 15$  V,  $\pm 20$  V, +12 V, and +36 V  
 $V_{DD}$  to  $V_{SS}$  analog signal range

## APPLICATIONS

High voltage signal routing  
 Automatic test equipment  
 Analog front-end circuits  
 Precision data acquisition  
 Amplifier gain select  
 Industrial instrumentation  
 Relay replacement

## GENERAL DESCRIPTION

The **ADG5401** is a monolithic industrial, complementary metal oxide semiconductor (CMOS) analog switch containing a latch-up immune single-pole/single-throw (SPST) switch. The switch conducts equally well in both directions when on, and has an input signal range that extends to the power supplies. In the off condition, signal levels up to the supplies are blocked.

The ultralow on resistance and on-resistance flatness of these switches make them ideal solutions for data acquisition and gain switching applications, where low distortion is critical. The latch-up immune construction and high ESD rating make these switches more robust in harsh environments.

## FUNCTIONAL BLOCK DIAGRAM

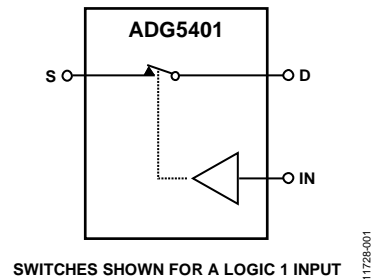

Figure 1.

## PRODUCT HIGHLIGHTS

1. Trench isolation guards against latch-up. A dielectric trench separates the P channel and N channel transistors, thereby preventing latch-up even under severe overvoltage conditions.
2. Low  $R_{ON}$  of 6.5  $\Omega$ .
3. Dual-supply operation. For applications where the analog signal is bipolar, the **ADG5401** can operate from dual supplies of up to  $\pm 22$  V.
4. Single-supply operation. For applications where the analog signal is unipolar, the **ADG5401** can operate from a single-rail power supply of up to 40 V.
5. 3 V logic compatible digital inputs:  $V_{INH} = 2.0$  V,  $V_{INL} = 0.8$  V.
6. No  $V_I$  logic power supply required.
7. Available in 8-lead MSOP package and 8-lead, 2 mm  $\times$  3 mm LFCSP packages.

Rev. A

[Document Feedback](#)

Information furnished by Analog Devices is believed to be accurate and reliable. However, no responsibility is assumed by Analog Devices for its use, nor for any infringements of patents or other rights of third parties that may result from its use. Specifications subject to change without notice. No license is granted by implication or otherwise under any patent or patent rights of Analog Devices. Trademarks and registered trademarks are the property of their respective owners.

**TABLE OF CONTENTS**

Features .....	1	Continuous Current per Channel, S or D.....	7
Applications.....	1	Absolute Maximum Ratings .....	8
Functional Block Diagram .....	1	ESD Caution.....	8
General Description .....	1	Pin Configurations and Function Descriptions .....	9
Product Highlights .....	1	Typical Performance Characteristics .....	10
Revision History .....	2	Test Circuits.....	13
Specifications.....	3	Terminology .....	15
±15 V Dual Supply .....	3	Applications Information .....	16
±20 V Dual Supply .....	4	Trench Isolation.....	16
12 V Single Supply.....	5	Outline Dimensions .....	17
36 V Single Supply.....	6	Ordering Guide .....	17

**REVISION HISTORY**

<b>1/15—Rev. 0 to Rev. A</b>		Changes to Figure 21 and Figure 26 .....	13
Added 8-Lead LFCSP.....	Universal	Added AC Power Supply Rejection Ratio (ACPSRR),	
Changed Continuous Current, S or D Parameter to 8-Lead		Terminology Section .....	15
MSOP, Table 5 .....	7	Added Figure 30, Outline Dimensions.....	17
Added Figure 2; Renumbered Sequentially .....	9	Changes to Ordering Guide.....	17
Changes to Table 7.....	9		
Changes to Figure 4.....	10		
Added Figure 19.....	12		
<b>9/13—Revision 0: Initial Version</b>			

## SPECIFICATIONS

### ±15 V DUAL SUPPLY

$V_{DD} = +15\text{ V} \pm 10\%$ ,  $V_{SS} = -15\text{ V} \pm 10\%$ ,  $GND = 0\text{ V}$ , unless otherwise noted.

Table 1.

Parameter	25°C	-40°C to +85°C	-40°C to +125°C	Unit	Test Conditions/Comments
<b>ANALOG SWITCH</b>					
Analogue Signal Range			$V_{DD}$ to $V_{SS}$	V	
On Resistance, $R_{ON}$	6.5 8	10	12	$\Omega$ typ $\Omega$ max	$V_S = \pm 10\text{ V}$ , $I_S = -10\text{ mA}$ ; see Figure 21 $V_{DD} = +13.5\text{ V}$ , $V_{SS} = -13.5\text{ V}$
On-Resistance Flatness, $R_{FLAT(ON)}$	1 1.4	1.7	2	$\Omega$ typ $\Omega$ max	$V_S = \pm 10\text{ V}$ , $I_S = -10\text{ mA}$
<b>LEAKAGE CURRENTS</b>					
Source Off Leakage, $I_S$ (Off)	$\pm 0.1$ $\pm 0.5$	$\pm 2$	$\pm 20$	nA typ nA max	$V_{DD} = +16.5\text{ V}$ , $V_{SS} = -16.5\text{ V}$ $V_S = \pm 10\text{ V}$ , $V_D = \mp 10\text{ V}$ ; see Figure 20
Drain Off Leakage, $I_D$ (Off)	$\pm 0.1$ $\pm 0.5$	$\pm 2$	$\pm 20$	nA typ nA max	$V_S = \pm 10\text{ V}$ , $V_D = \mp 10\text{ V}$ ; see Figure 20
Channel On Leakage, $I_D$ (On), $I_S$ (On)	$\pm 0.2$ $\pm 1$	$\pm 8$	$\pm 40$	nA typ nA max	$V_S = V_D = \pm 10\text{ V}$ ; see Figure 23
<b>DIGITAL INPUTS</b>					
Input High Voltage, $V_{INH}$			2.0	V min	
Input Low Voltage, $V_{INL}$			0.8	V max	
Input Current, $I_{INL}$ or $I_{INH}$	0.002		$\pm 0.1$	$\mu\text{A}$ typ $\mu\text{A}$ max	$V_{IN} = V_{GND}$ or $V_{DD}$
Digital Input Capacitance, $C_{IN}$	6			pF typ	
<b>DYNAMIC CHARACTERISTICS<sup>1</sup></b>					
$t_{ON}$	160 193	230	253	ns typ ns max	$R_L = 300\ \Omega$ , $C_L = 35\text{ pF}$ $V_S = 10\text{ V}$ ; see Figure 26
$t_{OFF}$	175 207	230	242	ns typ ns max	$R_L = 300\ \Omega$ , $C_L = 35\text{ pF}$ $V_S = 10\text{ V}$ ; see Figure 26
Charge Injection, $Q_{INJ}$	220			pC typ	$V_S = 0\text{ V}$ , $R_S = 0\ \Omega$ , $C_L = 1\text{ nF}$ ; see Figure 27
Off Isolation	-50			dB typ	$R_L = 50\ \Omega$ , $C_L = 5\text{ pF}$ , $f = 1\text{ MHz}$ ; see Figure 22
Total Harmonic Distortion + Noise (THD + N)	0.01			% typ	$R_L = 1\text{ k}\Omega$ , 15 V p-p, $f = 20\text{ Hz}$ to 20 kHz; see Figure 24
-3 dB Bandwidth	170			MHz typ	$R_L = 50\ \Omega$ , $C_L = 5\text{ pF}$ ; see Figure 25
Insertion Loss	-0.4			dB typ	$R_L = 50\ \Omega$ , $C_L = 5\text{ pF}$ , $f = 1\text{ MHz}$ ; see Figure 25
$C_S$ (Off)	22			pF typ	$V_S = 0\text{ V}$ , $f = 1\text{ MHz}$
$C_D$ (Off)	24			pF typ	$V_S = 0\text{ V}$ , $f = 1\text{ MHz}$
$C_D$ (On), $C_S$ (On)	75			pF typ	$V_S = 0\text{ V}$ , $f = 1\text{ MHz}$
<b>POWER REQUIREMENTS</b>					
$I_{DD}$	45 55		70	$\mu\text{A}$ typ $\mu\text{A}$ max	$V_{DD} = +16.5\text{ V}$ , $V_{SS} = -16.5\text{ V}$ Digital inputs = 0 V or $V_{DD}$
$I_{SS}$	0.001		1	$\mu\text{A}$ typ $\mu\text{A}$ max	Digital inputs = 0 V or $V_{DD}$
$V_{DD}/V_{SS}$			$\pm 9/\pm 22$	V min/V max	$GND = 0\text{ V}$

<sup>1</sup> Guaranteed by design; not subject to production test.

**±20 V DUAL SUPPLY**

$V_{DD} = +20\text{ V} \pm 10\%$ ,  $V_{SS} = -20\text{ V} \pm 10\%$ , GND = 0 V, unless otherwise noted.

Table 2.

Parameter	25°C	-40°C to +85°C	-40°C to +125°C	Unit	Test Conditions/Comments
<b>ANALOG SWITCH</b>					
Analogue Signal Range			$V_{DD}$ to $V_{SS}$	V	
On Resistance, $R_{ON}$	6			$\Omega$ typ	$V_S = \pm 15\text{ V}$ , $I_S = -10\text{ mA}$ ; see Figure 21
On-Resistance Flatness, $R_{FLAT(ON)}$	7	9	11	$\Omega$ max	$V_{DD} = +18\text{ V}$ , $V_{SS} = -18\text{ V}$
	1.2			$\Omega$ typ	$V_S = \pm 15\text{ V}$ , $I_S = -10\text{ mA}$
	1.7	2.1	2.5	$\Omega$ max	
<b>LEAKAGE CURRENTS</b>					
Source Off Leakage, $I_S$ (Off)	$\pm 0.1$			nA typ	$V_{DD} = +22\text{ V}$ , $V_{SS} = -22\text{ V}$ $V_S = \pm 15\text{ V}$ , $V_D = \mp 15\text{ V}$ ; see Figure 20
Drain Off Leakage, $I_D$ (Off)	$\pm 0.5$	$\pm 2$	$\pm 20$	nA max	$V_S = \pm 15\text{ V}$ , $V_D = \mp 15\text{ V}$ ; see Figure 20
	$\pm 0.1$			nA typ	
Channel On Leakage, $I_D$ (On), $I_S$ (On)	$\pm 0.5$	$\pm 2$	$\pm 20$	nA max	$V_S = V_D = \pm 15\text{ V}$ ; see Figure 23
	$\pm 0.2$			nA typ	
	$\pm 1$	$\pm 8$	$\pm 40$	nA max	
<b>DIGITAL INPUTS</b>					
Input High Voltage, $V_{INH}$			2.0	V min	$V_{IN} = V_{GND}$ or $V_{DD}$
Input Low Voltage, $V_{INL}$			0.8	V max	
Input Current, $I_{INL}$ or $I_{INH}$	0.002		$\pm 0.1$	$\mu\text{A}$ typ $\mu\text{A}$ max	
Digital Input Capacitance, $C_{IN}$	6			pF typ	
<b>DYNAMIC CHARACTERISTICS<sup>1</sup></b>					
$t_{ON}$	150			ns typ	$R_L = 300\ \Omega$ , $C_L = 35\text{ pF}$ $V_S = 10\text{ V}$ ; see Figure 26
	175	207	219	ns max	
$t_{OFF}$	170			ns typ	$R_L = 300\ \Omega$ , $C_L = 35\text{ pF}$ $V_S = 10\text{ V}$ ; see Figure 26
	196	214	223	ns max	
Charge Injection, $Q_{INJ}$	275			pC typ	$V_S = 0\text{ V}$ , $R_S = 0\ \Omega$ , $C_L = 1\text{ nF}$ ; see Figure 27
Off Isolation	-50			dB typ	$R_L = 50\ \Omega$ , $C_L = 5\text{ pF}$ , $f = 1\text{ MHz}$ ; see Figure 22
Total Harmonic Distortion + Noise (THD + N)	0.01			% typ	$R_L = 1\text{ k}\Omega$ , 20 V p-p, $f = 20\text{ Hz}$ to 20 kHz; see Figure 24
-3 dB Bandwidth	170			MHz typ	$R_L = 50\ \Omega$ , $C_L = 5\text{ pF}$ ; see Figure 25
Insertion Loss	-0.5			dB typ	$R_L = 50\ \Omega$ , $C_L = 5\text{ pF}$ , $f = 1\text{ MHz}$ ; see Figure 25
$C_S$ (Off)	21			pF typ	$V_S = 0\text{ V}$ , $f = 1\text{ MHz}$
$C_D$ (Off)	23			pF typ	$V_S = 0\text{ V}$ , $f = 1\text{ MHz}$
$C_D$ (On), $C_S$ (On)	75			pF typ	$V_S = 0\text{ V}$ , $f = 1\text{ MHz}$
<b>POWER REQUIREMENTS</b>					
$I_{DD}$	50			$\mu\text{A}$ typ	$V_{DD} = +22\text{ V}$ , $V_{SS} = -22\text{ V}$ Digital inputs = 0 V or $V_{DD}$
	70		110	$\mu\text{A}$ max	
$I_{SS}$	0.001			$\mu\text{A}$ typ	Digital inputs = 0 V or $V_{DD}$
			1	$\mu\text{A}$ max	
$V_{DD}/V_{SS}$			$\pm 9/\pm 22$	V min/V max	GND = 0 V

<sup>1</sup> Guaranteed by design; not subject to production test.

**12 V SINGLE SUPPLY**

$V_{DD} = 12\text{ V} \pm 10\%$ ,  $V_{SS} = 0\text{ V}$ ,  $GND = 0\text{ V}$ , unless otherwise noted.

**Table 3.**

Parameter	25°C	-40°C to +85°C	-40°C to +125°C	Unit	Test Conditions/Comments
<b>ANALOG SWITCH</b>					
Analog Signal Range			0 V to $V_{DD}$	V	
On Resistance, $R_{ON}$	14			$\Omega$ typ	$V_S = 0\text{ V to }10\text{ V}$ , $I_S = -10\text{ mA}$ ; see Figure 21
On-Resistance Flatness, $R_{FLAT(ON)}$	16	19	22	$\Omega$ max	$V_{DD} = 10.8\text{ V}$ , $V_{SS} = 0\text{ V}$
	2.8			$\Omega$ typ	$V_S = 0\text{ V to }10\text{ V}$ , $I_S = -10\text{ mA}$
	4	5.5	7	$\Omega$ max	
<b>LEAKAGE CURRENTS</b>					
Source Off Leakage, $I_S$ (Off)	$\pm 0.1$			nA typ	$V_{DD} = +13.2\text{ V}$ , $V_{SS} = 0\text{ V}$ $V_S = 1\text{ V to }10\text{ V}$ , $V_D = 10\text{ V to }1\text{ V}$ ; see Figure 20
Drain Off Leakage, $I_D$ (Off)	$\pm 0.5$	$\pm 2$	$\pm 20$	nA max	$V_S = 1\text{ V to }10\text{ V}$ , $V_D = 10\text{ V to }1\text{ V}$ ; see Figure 20
	$\pm 0.1$			nA typ	
Channel On Leakage, $I_D$ (On), $I_S$ (On)	$\pm 0.5$	$\pm 2$	$\pm 20$	nA max	$V_S = V_D = 1\text{ V to }10\text{ V}$ ; see Figure 23
	$\pm 0.2$			nA typ	
	$\pm 1$	$\pm 8$	$\pm 40$	nA max	
<b>DIGITAL INPUTS</b>					
Input High Voltage, $V_{INH}$			2.0	V min	$V_{IN} = V_{GND}$ or $V_{DD}$
Input Low Voltage, $V_{INL}$			0.8	V max	
Input Current, $I_{INL}$ or $I_{INH}$	0.002			$\mu\text{A}$ typ	
Digital Input Capacitance, $C_{IN}$	6		$\pm 0.1$	$\mu\text{A}$ max pF typ	
<b>DYNAMIC CHARACTERISTICS<sup>1</sup></b>					
$t_{ON}$	260	406	454	ns typ	$R_L = 300\ \Omega$ , $C_L = 35\text{ pF}$
	327			ns max	$V_S = 8\text{ V}$ ; see Figure 26
$t_{OFF}$	200	280	300	ns typ	$R_L = 300\ \Omega$ , $C_L = 35\text{ pF}$
	244			ns max	$V_S = 8\text{ V}$ ; see Figure 26
Charge Injection, $Q_{INU}$	95			pC typ	$V_S = 6\text{ V}$ , $R_S = 0\ \Omega$ , $C_L = 1\text{ nF}$ ; see Figure 27
Off Isolation	-50			dB typ	$R_L = 50\ \Omega$ , $C_L = 5\text{ pF}$ , $f = 1\text{ MHz}$ ; see Figure 22
Total Harmonic Distortion + Noise (THD + N)	0.02			% typ	$R_L = 1\text{ k}\Omega$ , 6 V p-p, $f = 20\text{ Hz to }20\text{ kHz}$ ; see Figure 24
-3 dB Bandwidth	190			MHz typ	$R_L = 50\ \Omega$ , $C_L = 5\text{ pF}$ ; see Figure 25
Insertion Loss	-0.9			dB typ	$R_L = 50\ \Omega$ , $C_L = 5\text{ pF}$ , $f = 1\text{ MHz}$ ; see Figure 25
$C_S$ (Off)	28			pF typ	$V_S = 6\text{ V}$ , $f = 1\text{ MHz}$
$C_D$ (Off)	30			pF typ	$V_S = 6\text{ V}$ , $f = 1\text{ MHz}$
$C_D$ (On), $C_S$ (On)	60			pF typ	$V_S = 6\text{ V}$ , $f = 1\text{ MHz}$
<b>POWER REQUIREMENTS</b>					
$I_{DD}$	40			$\mu\text{A}$ typ	$V_{DD} = 13.2\text{ V}$
	50		65	$\mu\text{A}$ max	Digital inputs = 0 V or $V_{DD}$
$V_{DD}$			9/40	V min/V max	$GND = 0\text{ V}$ , $V_{SS} = 0\text{ V}$

<sup>1</sup> Guaranteed by design; not subject to production test.

**36 V SINGLE SUPPLY**

$V_{DD} = 36\text{ V} \pm 10\%$ ,  $V_{SS} = 0\text{ V}$ ,  $GND = 0\text{ V}$ , unless otherwise noted.

**Table 4.**

Parameter	25°C	-40°C to +85°C	-40°C to +125°C	Unit	Test Conditions/Comments
<b>ANALOG SWITCH</b>					
Analog Signal Range			0 V to $V_{DD}$	V	
On Resistance, $R_{ON}$	7			$\Omega$ typ	$V_S = 0\text{ V to }30\text{ V}$ , $I_S = -10\text{ mA}$ ; see Figure 21
On-Resistance Flatness, $R_{FLAT(ON)}$	9	11	13	$\Omega$ max	$V_{DD} = 32.4\text{ V}$ , $V_{SS} = 0\text{ V}$
	1.8			$\Omega$ typ	$V_S = 0\text{ V to }30\text{ V}$ , $I_S = -10\text{ mA}$
	2.6	3	3.5	$\Omega$ max	
<b>LEAKAGE CURRENTS</b>					
Source Off Leakage, $I_S$ (Off)	$\pm 0.1$			nA typ	$V_{DD} = +39.6\text{ V}$ , $V_{SS} = 0\text{ V}$ $V_S = 1\text{ V to }30\text{ V}$ , $V_D = 30\text{ V to }1\text{ V}$ ; see Figure 20
Drain Off Leakage, $I_D$ (Off)	$\pm 0.5$	$\pm 2$	$\pm 20$	nA max	$V_S = 1\text{ V to }30\text{ V}$ , $V_D = 30\text{ V to }1\text{ V}$ ; see Figure 20
	$\pm 0.1$			nA typ	
Channel On Leakage, $I_D$ (On), $I_S$ (On)	$\pm 0.5$	$\pm 2$	$\pm 20$	nA max	$V_S = V_D = 1\text{ V to }30\text{ V}$ ; see Figure 23
	$\pm 0.2$			nA typ	
	$\pm 1$	$\pm 8$	$\pm 40$	nA max	
<b>DIGITAL INPUTS</b>					
Input High Voltage, $V_{INH}$			2.0	V min	$V_{IN} = V_{GND}$ or $V_{DD}$
Input Low Voltage, $V_{INL}$			0.8	V max	
Input Current, $I_{INL}$ or $I_{INH}$	0.002		$\pm 0.1$	$\mu\text{A}$ typ $\mu\text{A}$ max	
Digital Input Capacitance, $C_{IN}$	6			pF typ	
<b>DYNAMIC CHARACTERISTICS<sup>1</sup></b>					
$t_{ON}$	160	212	230	ns typ	$R_L = 300\ \Omega$ , $C_L = 35\text{ pF}$ $V_S = 18\text{ V}$ ; see Figure 26
	187			ns max	
$t_{OFF}$	180	221	225	ns typ	$R_L = 300\ \Omega$ , $C_L = 35\text{ pF}$ $V_S = 18\text{ V}$ ; see Figure 26
	213			ns max	
Charge Injection, $Q_{INU}$	255			pC typ	$V_S = 18\text{ V}$ , $R_S = 0\ \Omega$ , $C_L = 1\text{ nF}$ ; see Figure 27
Off Isolation	-50			dB typ	$R_L = 50\ \Omega$ , $C_L = 5\text{ pF}$ , $f = 1\text{ MHz}$ ; see Figure 22
Total Harmonic Distortion + Noise (THD + N)	0.01			% typ	$R_L = 1\text{ k}\Omega$ , 18 V p-p, $f = 20\text{ Hz to }20\text{ kHz}$ ; see Figure 24
-3 dB Bandwidth	170			MHz typ	$R_L = 50\ \Omega$ , $C_L = 5\text{ pF}$ ; see Figure 25
Insertion Loss	-0.55			dB typ	$R_L = 50\ \Omega$ , $C_L = 5\text{ pF}$ , $f = 1\text{ MHz}$ ; see Figure 25
$C_S$ (Off)	26			pF typ	$V_S = 18\text{ V}$ , $f = 1\text{ MHz}$
$C_D$ (Off)	28			pF typ	$V_S = 18\text{ V}$ , $f = 1\text{ MHz}$
$C_D$ (On), $C_S$ (On)	65			pF typ	$V_S = 18\text{ V}$ , $f = 1\text{ MHz}$
<b>POWER REQUIREMENTS</b>					
$I_{DD}$	80			$\mu\text{A}$ typ	$V_{DD} = 39.6\text{ V}$ Digital inputs = 0 V or $V_{DD}$
	100		130	$\mu\text{A}$ max	
$V_{DD}$			9/40	V min/V max	$GND = 0\text{ V}$ , $V_{SS} = 0\text{ V}$

<sup>1</sup> Guaranteed by design; not subject to production test.

**CONTINUOUS CURRENT PER CHANNEL, S OR D**

Table 5.

Parameter	25°C	85°C	125°C	Unit	Test Condition/Comments
8-LEAD MSOP					$\theta_{JA} = 133.1^{\circ}\text{C/W}$
$V_{DD} = 15\text{ V}, V_{SS} = -15\text{ V}$	171	116	79	mA maximum	
$V_{DD} = 20\text{ V}, V_{SS} = -20\text{ V}$	177	120.5	81	mA maximum	
$V_{DD} = 12\text{ V}, V_{SS} = 0\text{ V}$	139	99	70	mA maximum	
$V_{DD} = 36\text{ V}, V_{SS} = 0\text{ V}$	174	118	81	mA maximum	
8-LEAD LFCSP					$\theta_{JA} = 60.88^{\circ}\text{C/W}$
$V_{DD} = 15\text{ V}, V_{SS} = -15\text{ V}$	234	150	93	mA maximum	
$V_{DD} = 20\text{ V}, V_{SS} = -20\text{ V}$	246	155	95	mA maximum	
$V_{DD} = 12\text{ V}, V_{SS} = 0\text{ V}$	193	130	85	mA maximum	
$V_{DD} = 36\text{ V}, V_{SS} = 0\text{ V}$	241	153	95	mA maximum	

## ABSOLUTE MAXIMUM RATINGS

$T_A = 25^\circ\text{C}$ , unless otherwise noted.

**Table 6.**

Parameter	Rating
$V_{DD}$ to $V_{SS}$	48 V
$V_{DD}$ to GND	-0.3 V to +48 V
$V_{SS}$ to GND	+0.3 V to -48 V
Analog Inputs <sup>1</sup>	$V_{SS} - 0.3\text{ V}$ to $V_{DD} + 0.3\text{ V}$ or 30 mA, whichever occurs first
Digital Inputs <sup>1</sup>	$V_{SS} - 0.3\text{ V}$ to $V_{DD} + 0.3\text{ V}$ or 30 mA, whichever occurs first
Peak Current, S or D Pin	630 mA (pulsed at 1 ms, 10% duty cycle maximum)
Continuous Current, S or D <sup>2</sup>	Data + 15%
Temperature Range	
Operating	-40°C to +125°C
Storage	-65°C to +150°C
Junction Temperature	150°C
Thermal Impedance, $\theta_{JA}$	
8-Lead MSOP (4-Layer Board)	133.1°C/W
8-Lead LFCSP	60.88°C/W
Reflow Soldering Peak Temperature, Pb Free	As per JEDEC J-STD-020
Human Body Model (HBM) ESD	8 kV

<sup>1</sup> Overvoltages at the IN, S, and D pins are clamped by internal diodes. Limit current to the maximum ratings given.

<sup>2</sup> See Table 5.

Stresses at or above those listed under Absolute Maximum Ratings may cause permanent damage to the product. This is a stress rating only; functional operation of the product at these or any other conditions above those indicated in the operational section of this specification is not implied. Operation beyond the maximum operating conditions for extended periods may affect product reliability.

Only one absolute maximum rating can be applied at any one time.

### ESD CAUTION



**ESD (electrostatic discharge) sensitive device.** Charged devices and circuit boards can discharge without detection. Although this product features patented or proprietary protection circuitry, damage may occur on devices subjected to high energy ESD. Therefore, proper ESD precautions should be taken to avoid performance degradation or loss of functionality.

## PIN CONFIGURATIONS AND FUNCTION DESCRIPTIONS

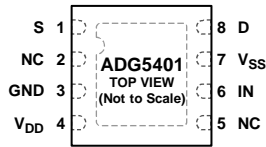

NOTES  
 1. NC = NO CONNECT. NOT INTERNALLY CONNECTED.  
 2. THE EXPOSED PAD IS TIED TO SUBSTRATE, V<sub>SS</sub>.

11728-102

Figure 2. 8-Lead LFCSP Pin Configuration

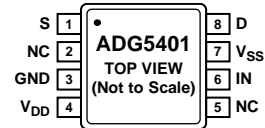

NOTES  
 1. NC = NO CONNECT. NOT INTERNALLY CONNECTED.

11728-002

Figure 3. 8-Lead MSOP Pin Configuration

Table 7. Pin Function Descriptions

Pin No.		Mnemonic	Description
8-Lead LFCSP	8-Lead MSOP		
1	1	S	Source Terminal. This pin can be an input or output.
2	2	NC	No Connect. Not internally connected.
3	3	GND	Ground (0 V) Reference.
4	4	V <sub>DD</sub>	Most Positive Power Supply Potential.
5	5	NC	No Connect. Not internally connected.
6	6	IN	Logic Control Input.
7	7	V <sub>SS</sub>	Most Negative Power Supply Potential.
8	8	D	Drain Terminal. This pin can be an input or output.
	Not applicable	EPAD	The exposed pad is tied to substrate, V <sub>SS</sub> .

Table 8. Truth Table

IN	Switch Condition
1	On
0	Off

TYPICAL PERFORMANCE CHARACTERISTICS

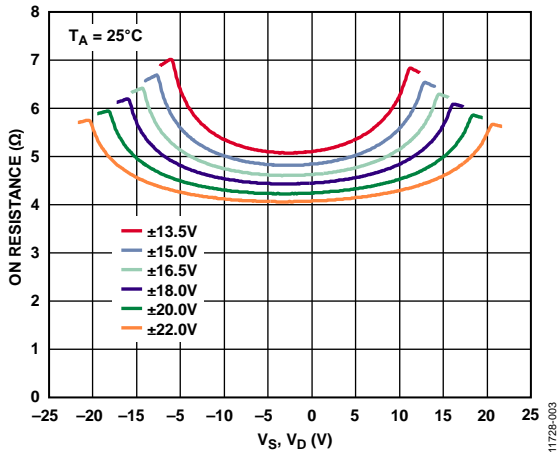

Figure 4. On Resistance as a Function of  $V_S, V_D$  (Dual Supply)

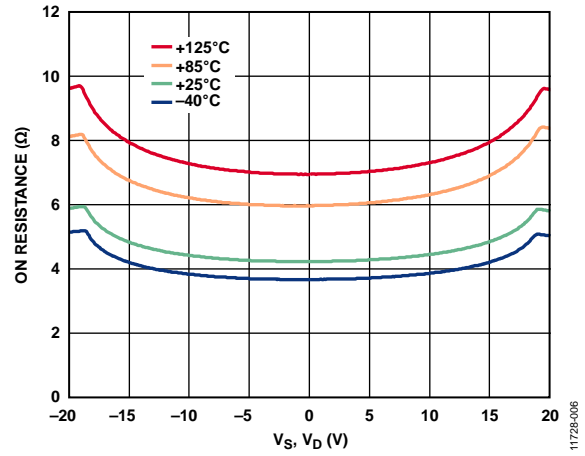

Figure 7. On Resistance as a Function of  $V_S (V_D)$  for Different Temperatures,  $\pm 20$  V Dual Supply

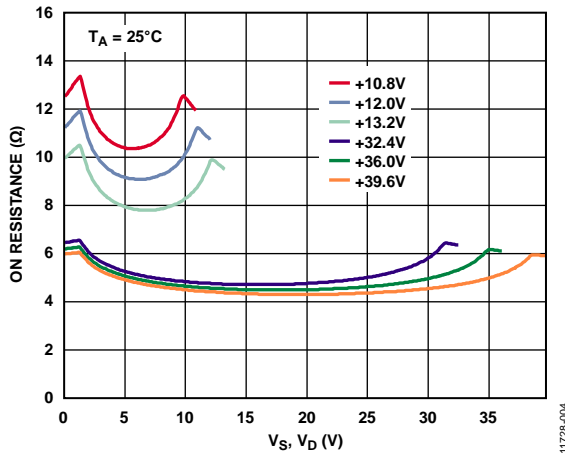

Figure 5. On Resistance as a Function of  $V_S, V_D$  (Single Supply)

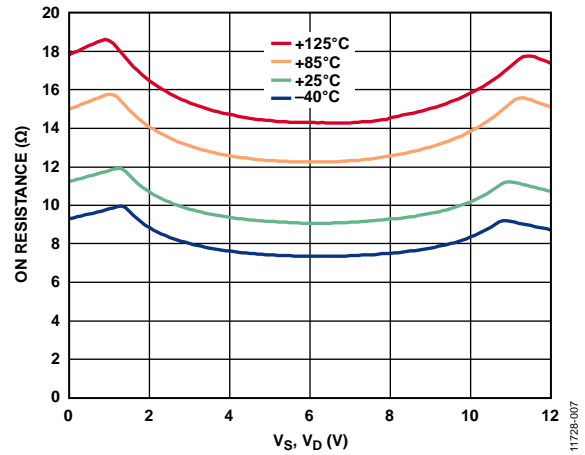

Figure 8. On Resistance as a Function of  $V_S (V_D)$  for Different Temperatures, 12 V Single Supply

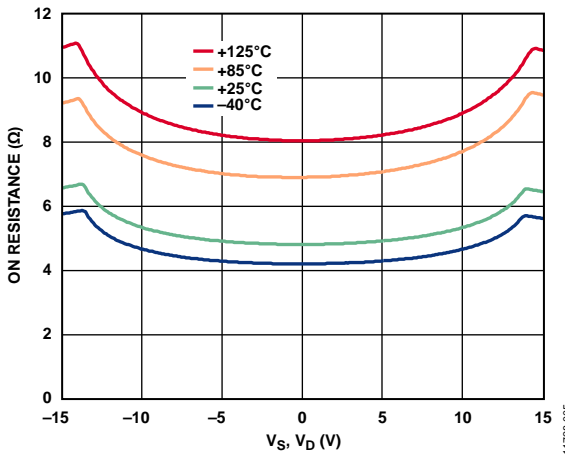

Figure 6. On Resistance as a Function of  $V_S (V_D)$  for Different Temperatures,  $\pm 15$  V Dual Supply

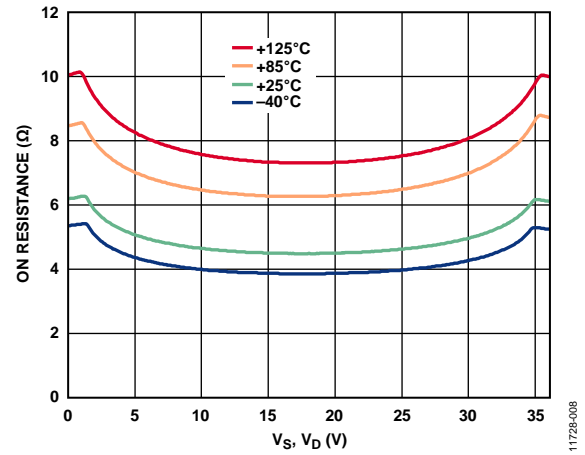

Figure 9. On Resistance as a Function of  $V_S (V_D)$  for Different Temperatures, 36 V Single Supply

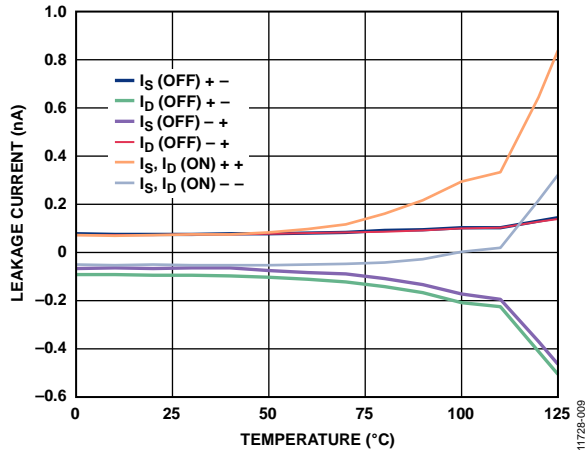

Figure 10. Leakage Currents as a Function of Temperature, ±15 V Dual Supply

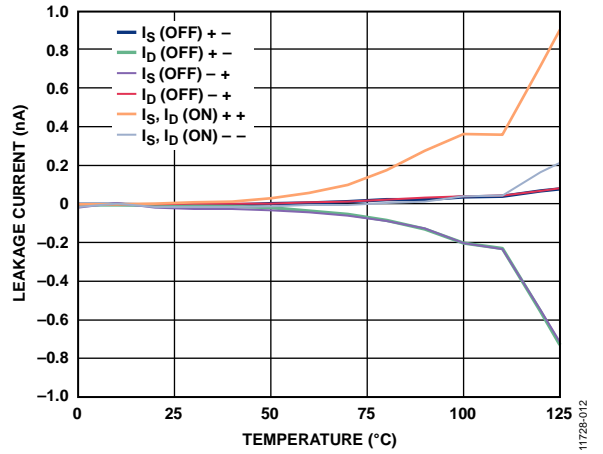

Figure 13. Leakage Currents as a Function of Temperature, 36 V Single Supply

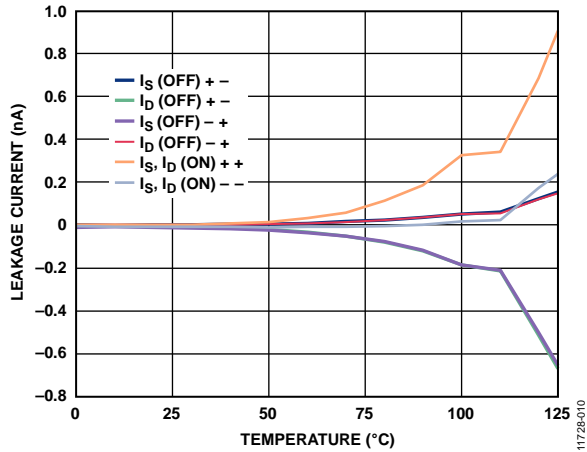

Figure 11. Leakage Currents as a Function of Temperature, ±20 V Dual Supply

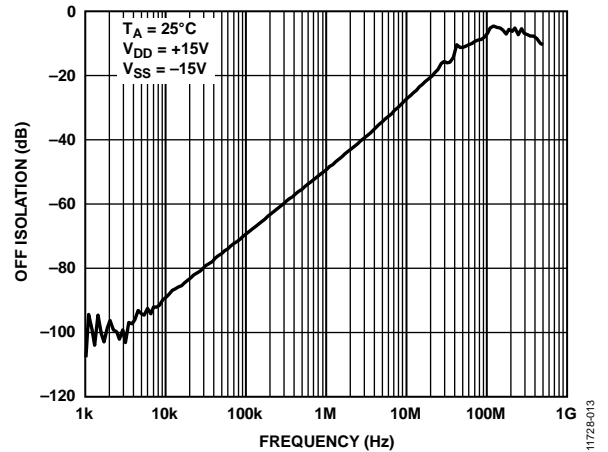

Figure 14. Off Isolation vs. Frequency

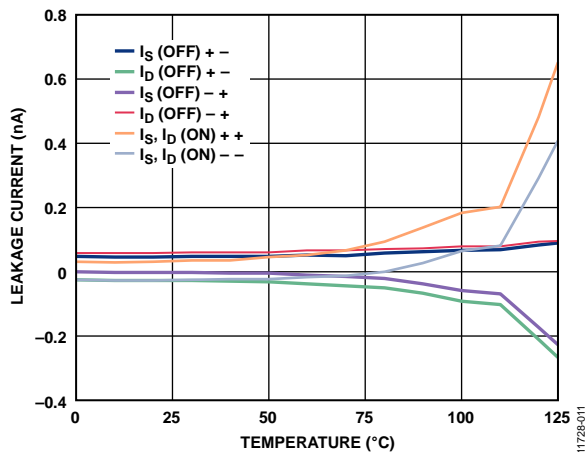

Figure 12. Leakage Currents as a Function of Temperature, 12 V Single Supply

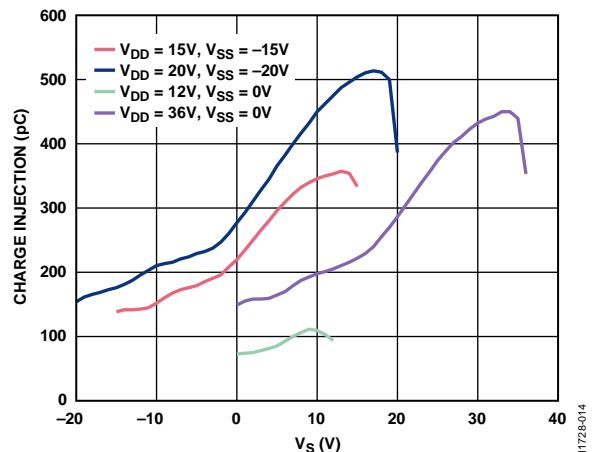

Figure 15. Charge Injection vs. Source Voltage ( $V_S$ )

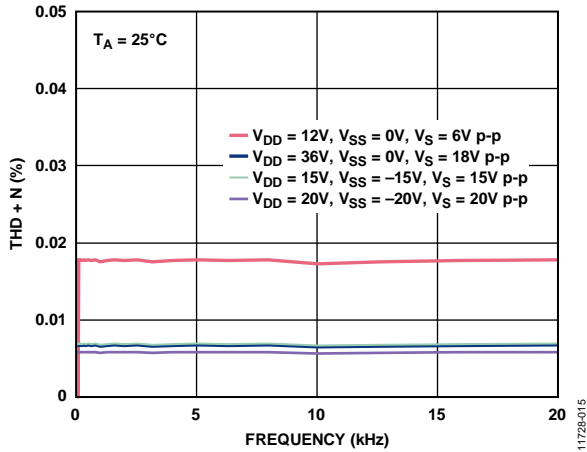

Figure 16. THD + N vs. Frequency

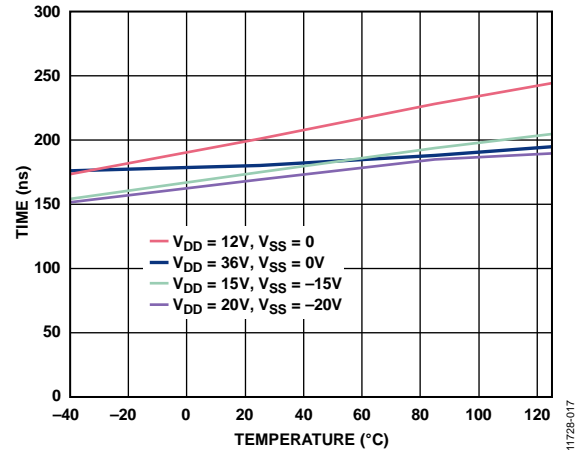

Figure 18.  $t_{\text{TRANSITION}}$  Times vs. Temperature

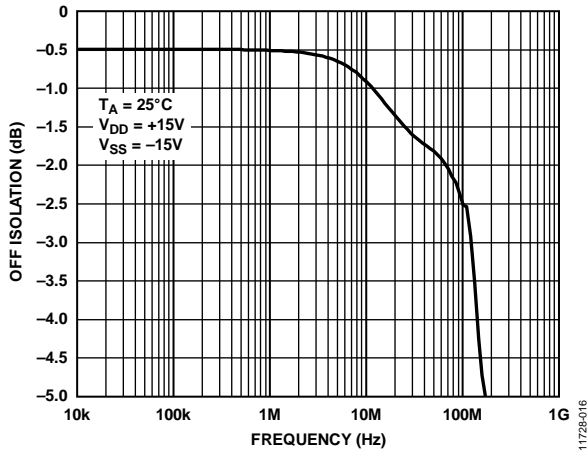

Figure 17. Bandwidth

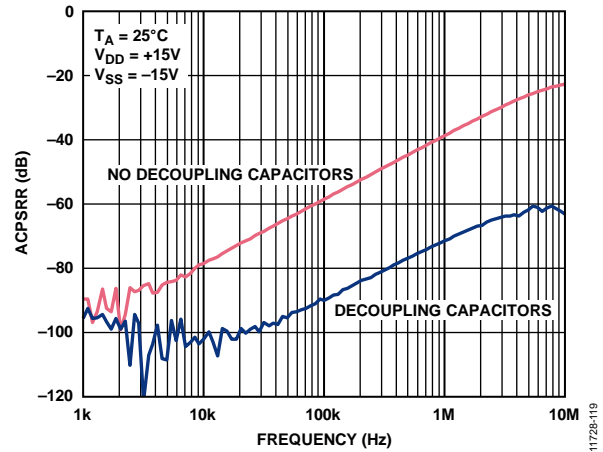

Figure 19. ACPSRR vs. Frequency

TEST CIRCUITS

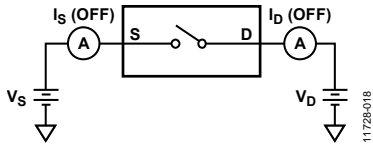

Figure 20. Off Leakage

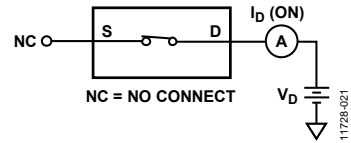

Figure 23. On Leakage

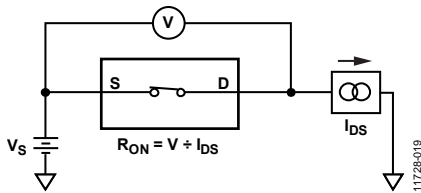

Figure 21. On Resistance

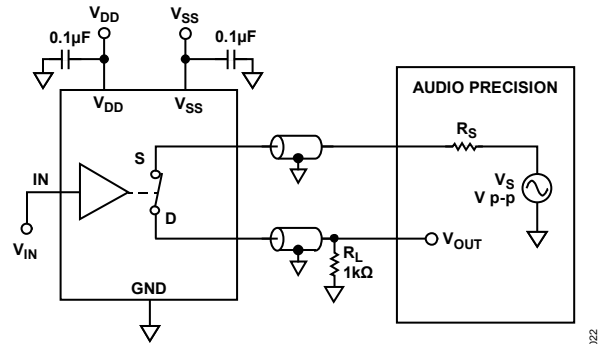

Figure 24. THD + N

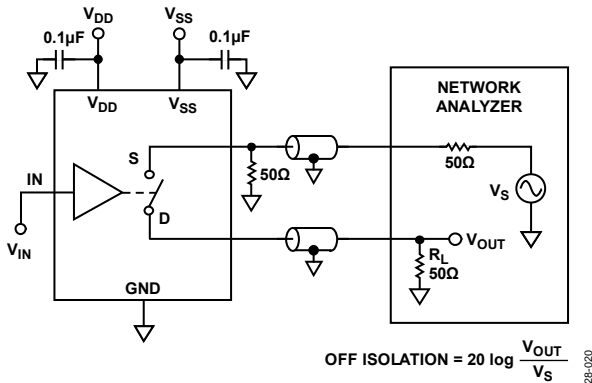

Figure 22. Off Isolation

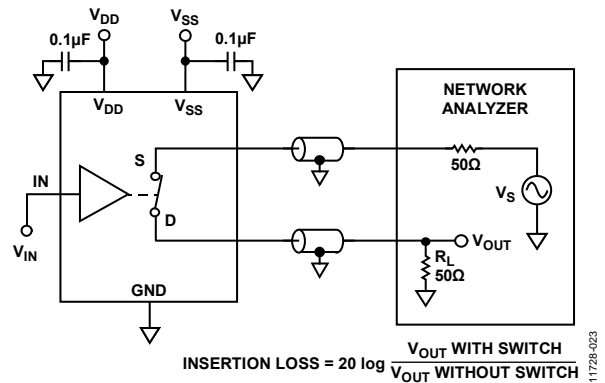

Figure 25. Bandwidth

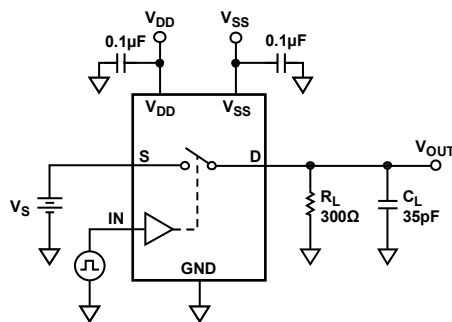
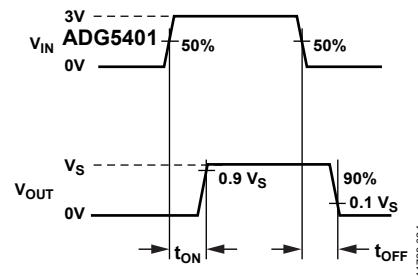

Figure 26. Switching Times, tON and tOFF



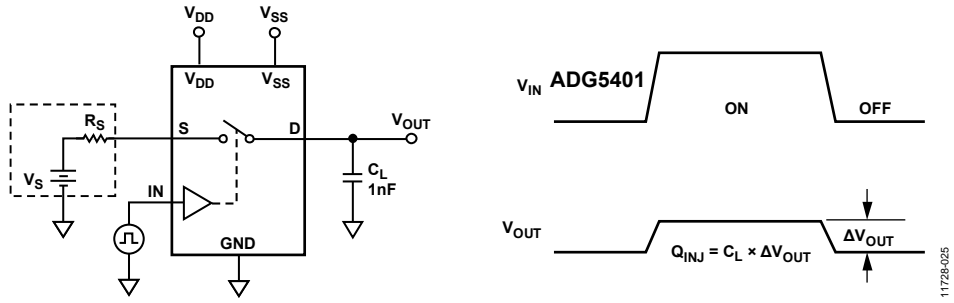

Figure 27. Charge Injection

11728-025

## TERMINOLOGY

### $I_{DD}$

$I_{DD}$  represents the positive supply current.

### $I_{SS}$

$I_{SS}$  represents the negative supply current.

### $V_D, V_S$

$V_D$  and  $V_S$  represent the analog voltage on Terminal D and Terminal S, respectively.

### $R_{ON}$

$R_{ON}$  is the ohmic resistance between Terminal D and Terminal S.

### $R_{FLAT(ON)}$

$R_{FLAT(ON)}$  represents the difference between the maximum and minimum value of on resistance as measured over the specified analog signal range.

### $I_S$ (Off)

$I_S$  (Off) is the source leakage current with the switch off.

### $I_D$ (Off)

$I_D$  (Off) is the drain leakage current with the switch off.

### $I_D$ (On), $I_S$ (On)

$I_D$  (On) and  $I_S$  (On) represent the channel leakage currents with the switch on.

### $V_{INL}$

$V_{INL}$  is the maximum input voltage for Logic 0.

### $V_{INH}$

$V_{INH}$  is the minimum input voltage for Logic 1.

### $I_{INL}, I_{INH}$

$I_{INL}$  and  $I_{INH}$  represent the low and high input currents of the digital inputs.

### $C_D$ (Off)

$C_D$  (Off) represents the off switch drain capacitance, which is measured with reference to ground.

### $C_S$ (Off)

$C_S$  (Off) represents the off switch source capacitance, which is measured with reference to ground.

### $C_D$ (On), $C_S$ (On)

$C_D$  (On) and  $C_S$  (On) represent the on switch capacitances, which are measured with reference to ground.

### $C_{IN}$

$C_{IN}$  represents digital input capacitance.

### $t_{ON}$

$t_{ON}$  represents the delay time between the 50% and 90% points of the digital input and switch on condition.

### $t_{OFF}$

$t_{OFF}$  represents the delay time between the 50% and 90% points of the digital input and switch off condition.

### Off Isolation

Off isolation is a measure of unwanted signal coupling through an off channel.

### Charge Injection

Charge injection is a measure of the glitch impulse transferred from the digital input to the analog output during switching.

### Bandwidth

Bandwidth is the frequency at which the output is attenuated by 3 dB from its dc value.

### Total Harmonic Distortion + Noise (THD + N)

The ratio of the harmonic amplitude plus noise of the signal to the fundamental is represented by THD + N.

### AC Power Supply Rejection Ratio (ACPSRR)

ACPSRR measures the ability of the device to avoid coupling noise and spurious signals that appear on the supply voltage pin to the output of the switch. The dc voltage on the device is modulated by a sine wave of 0.62 V p-p. The ratio of the amplitude of the signal on the output to the amplitude of the modulation is the ACPSRR (see Figure 19).

## APPLICATIONS INFORMATION

The [ADG54xx](#) family of switches and multiplexers provide a robust solution for instrumentation, industrial, aerospace, and other harsh environments that are prone to latch-up, which is an undesirable high current state that can lead to device failure and persists until the power supply is turned off. The [ADG5401](#) high voltage switch allows single-supply operation from 9 V to 40 V and dual-supply operation from  $\pm 9$  V to  $\pm 22$  V. The [ADG5401](#) (as well as other select devices within this family) achieves an 8 kV human body model ESD rating, which provides a robust solution, eliminating the need for separate protection circuitry designs in some applications.

### TRENCH ISOLATION

In the [ADG5401](#), an insulating oxide layer (trench) is placed between the NMOS and the PMOS transistors of each CMOS switch. Parasitic junctions, which occur between the transistors in junction-isolated switches, are eliminated, and the result is a latch-up immune switch.

In junction isolation, the N and P wells of the PMOS and NMOS transistors form a diode that is reverse-biased under normal operation. However, during overvoltage conditions, this diode can become forward-biased. The two transistors form a silicon-controlled rectifier (SCR) type circuit, causing a significant amplification of the current that, in turn, leads to latch-up. With trench isolation, this diode is removed, and the result is a latch-up immune switch.

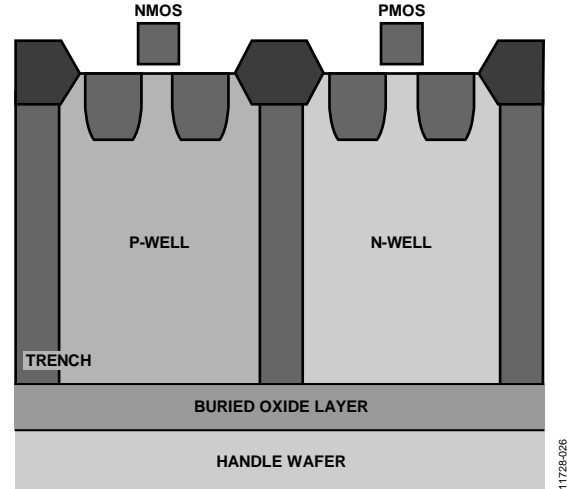
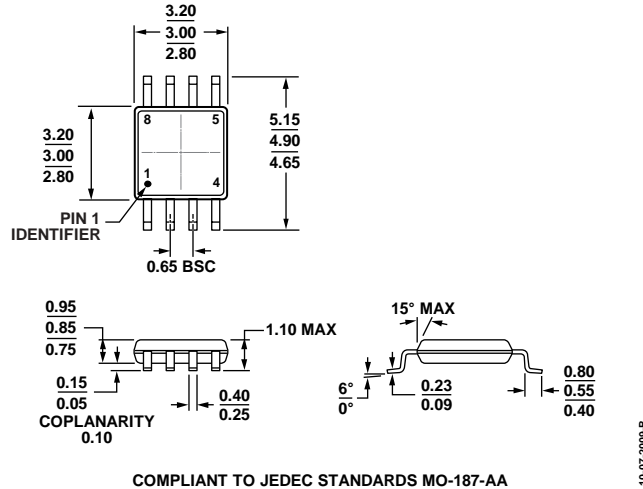

Figure 28. Trench Isolation

# OUTLINE DIMENSIONS



COMPLIANT TO JEDEC STANDARDS MO-187-AA  
 Figure 29. 8-Lead Mini Small Outline Package [MSOP]  
 (RM-8)  
 Dimensions shown in millimeters

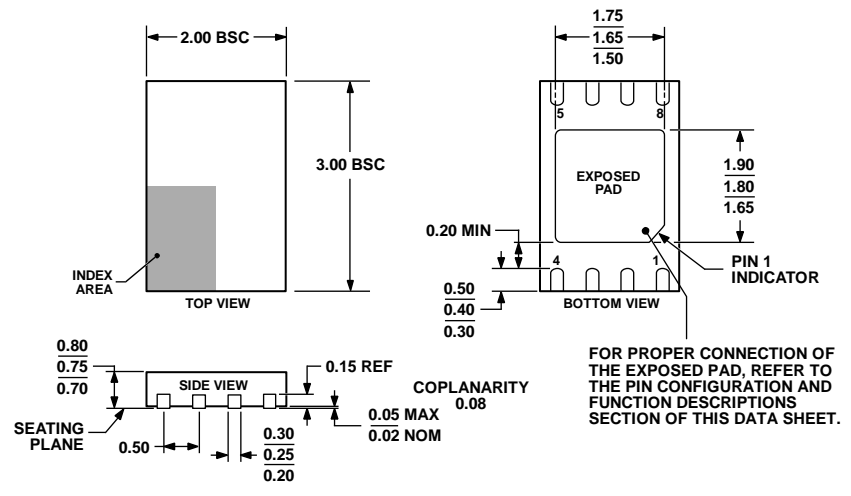

Figure 30. 8-Lead Lead Frame Chip Scale Package [LFCS\_P\_WD]  
 2 mm x 3 mm Body, Very Very Thin, Dual Lead  
 (CP-8-4)  
 Dimensions shown in millimeters

## ORDERING GUIDE

Model <sup>1</sup>	Temperature Range	Package Description	Package Option	Branding
ADG5401BRMZ	-40°C to +125°C	8-Lead Mini Small Outline Package [MSOP]	RM-8	S2M
ADG5401BRMZ-RL7	-40°C to +125°C	8-Lead Mini Small Outline Package [MSOP]	RM-8	S2M
ADG5401BCPZ-RL7	-40°C to +125°C	8-Lead Lead Frame Chip Scale Package [LFCS_P_WD]	CP-8-4	BR

<sup>1</sup> Z = RoHS Compliant Part.